

1 2 3 4 5 6 7 8

A  
B  
C  
D  
E  
F

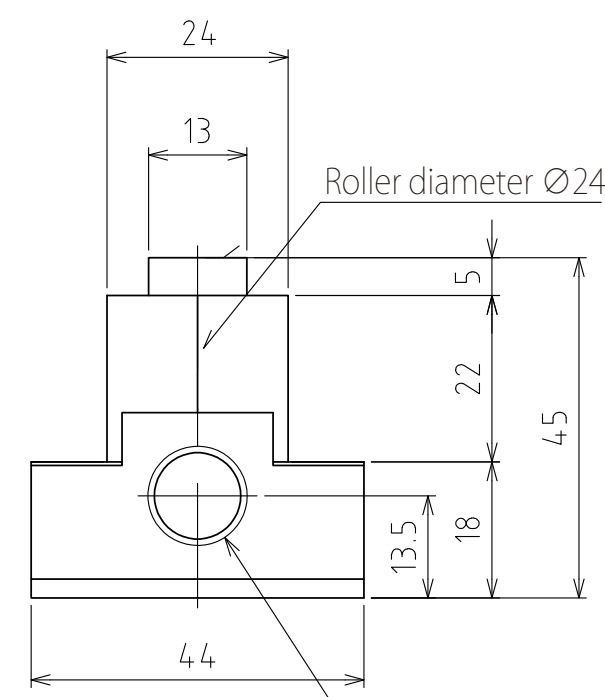
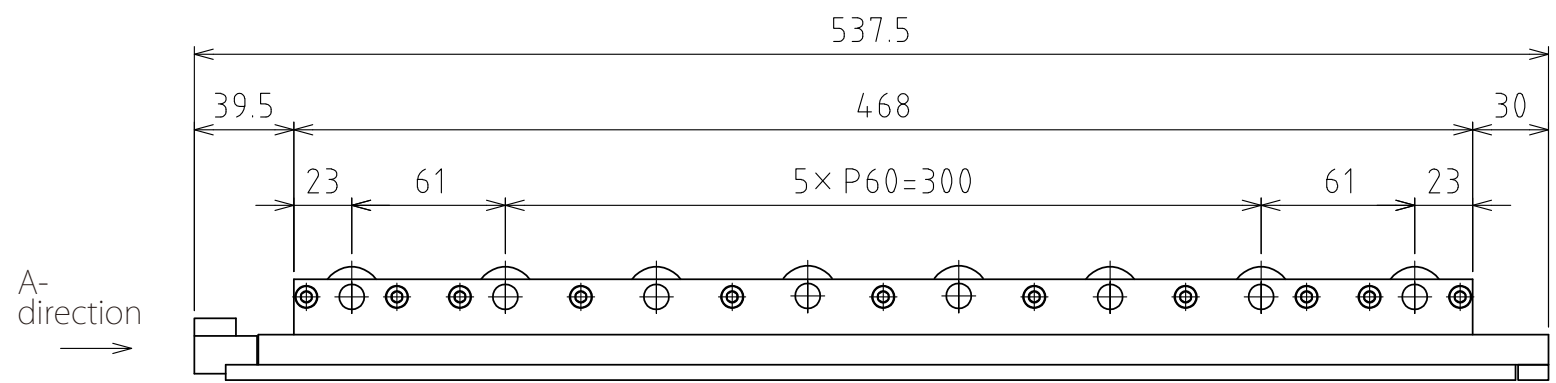
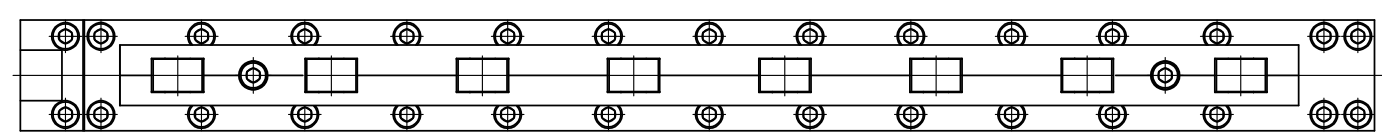

Roller diameter  $\varnothing 24$

Rc1/4

View A

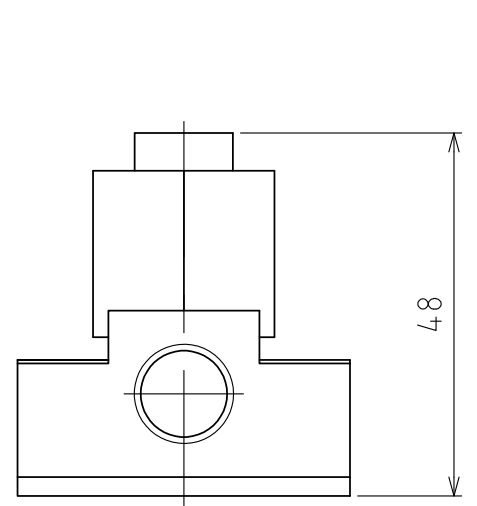

Rising  
(stroke 3mm)

(Scale 1:1)

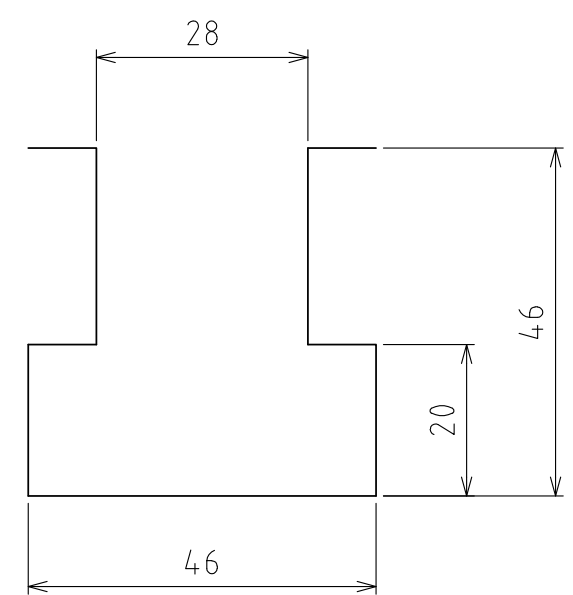

T-groove size

spec

Series	ARU-2444 series	
Material	Roller	SUJ2
	Shaft	SK3
	Body	Steel
Means to lower the balls	Spring return system (lowers by exhausting)	
Weight	4.5kg	

Capacity	Air pressure [ MPa(kgf/cm <sup>2</sup> ) ]	Load capacity (Unit) [ kN(kgf) ]
	0.3 (3.1)	2.46(250.1)
	0.4 (4.1)	2.94(299.8)
	0.5 (5.1)	3.92(399.8)
	0.6 (6.1)	4.91(500.1)

設計 DESIGNED BY	古内	2021/07/26	名称 TITLE
製図 DRAWN BY	古内	2021/07/26	
検図 CHECKED BY	技術部 坂根	承認 APPROVED BY	技術部 花村
尺度 SCALE	1:3	サイズ SIZE	A3
第三角法			☉
FREEBEAR			図面番号 DRAWING NO. SAU05802-F03
			変更回数 REV.MARK

1 2 3 4 5 6 7 8