

Pneumatically Actuated Roller Unit
T-groove insertion type ARU-2444 Series
Instruction Manual

Thank you for purchasing our product.

Before use, please carefully read the following instructions to ensure proper usage.

We appreciate your cooperation.

1. Summary

This product is a device that assists in the transportation of items through built-in roller, and its operation is controlled by air pressure.

2. Safety Precautions

- Operating air pressure : Use within the range of 0.3MPa to 0.6Mpa.
- Usage environment : For general indoor use.

(0°C to 60°C, avoid freezing and condensation)

※Heat-resistant specifications can be customized upon request.

- Ensure that water or foreign objects do not enter the compressed air system.
- When not in use, release the internal compressed air.
- Avoid severe impact to the product.
- Do not disassemble or modify the product.

3. Installation Method

Please insert this product into the groove where it is to be installed.

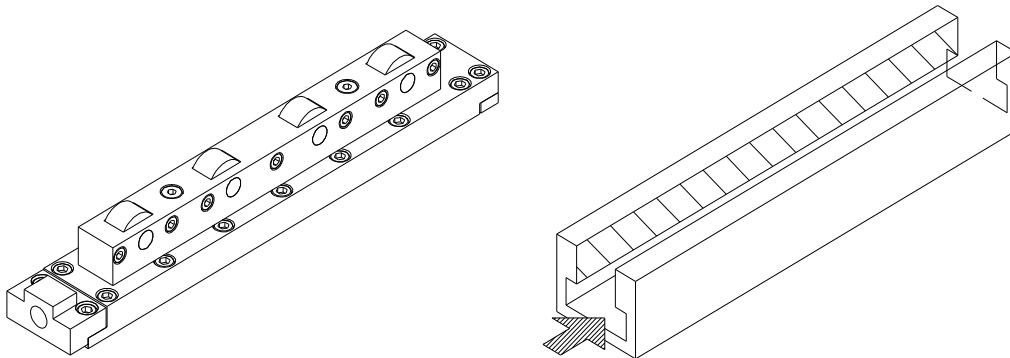

4. Piping Connection

The pneumatic circuit diagram of this product is shown below

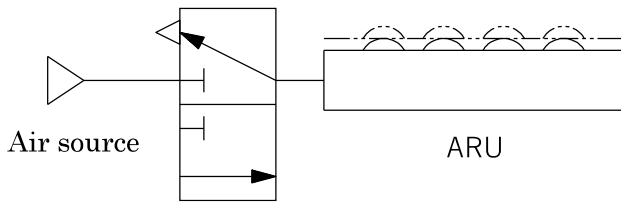

2-position 3-port valve

This product is equipped with a spring-return piston.
After releasing the compressed air, roller will descend.

5. Connection Method

This product can be connected using the following methods.

Parts removal

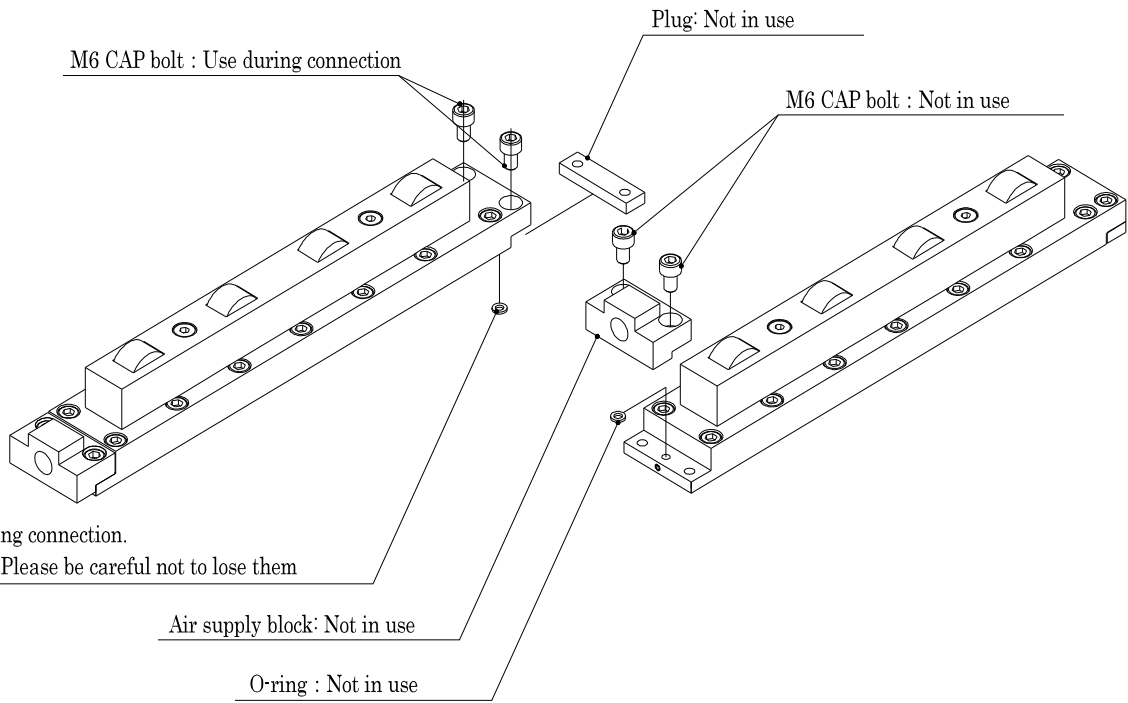

Parts connection

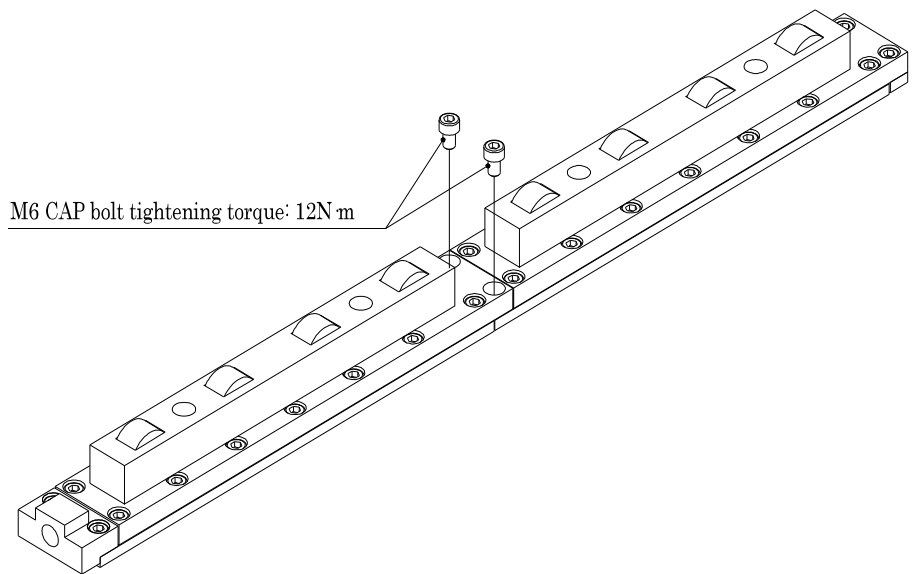

6. Height Adjustment Method

The height of this product can be adjusted using separately sold spacers.

Parts removal

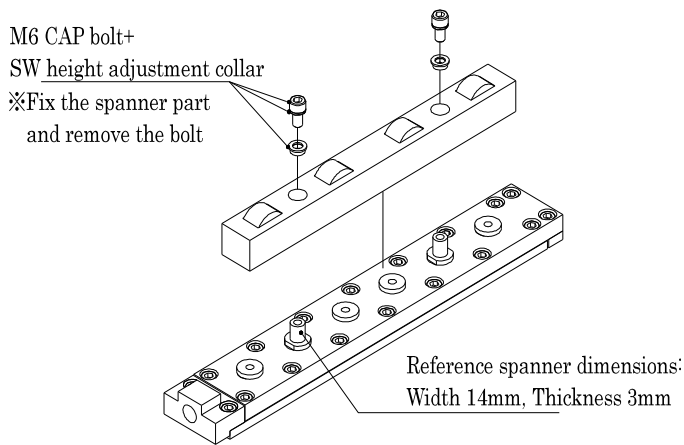

Installation of spacer

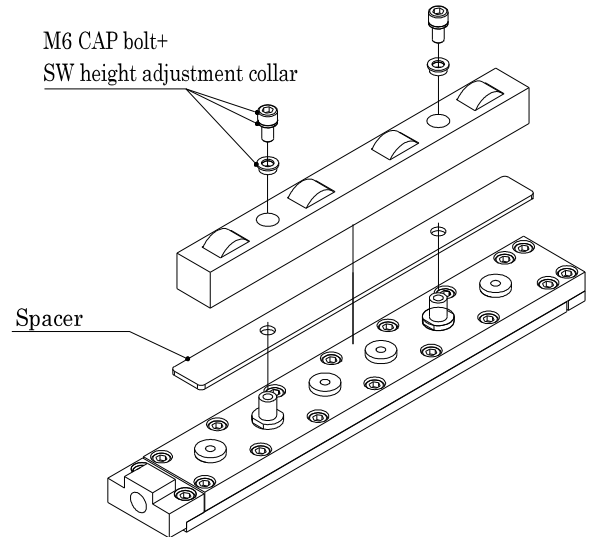

※Please provide air to float the roller before proceeding.

Adjust height using spacers (thickness and number)

※It is necessary to change the collar and bolt at the same time.

7. Precautions for Use

- ① When placing and moving transported items on this product, ensure that when rollers rise to the highest point, the top surface remains level with the contact surface of the item.

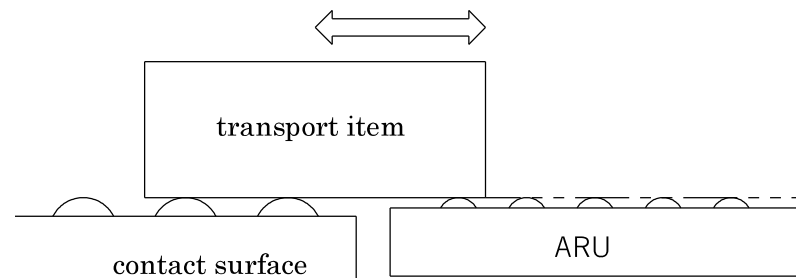

- ② When the transported item cannot be supported by all rollers, the load capacity and the transportation ability of this product may decrease.

For example,

- a) lightening holes on the bottom
- b) protrusions on the bottom
- c) holes on the bottom, etc.

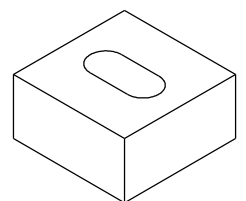
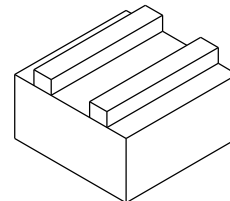
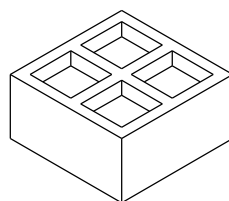

- ③ Please set up this product on a flat surface without unevenness.
- ④ Do not clamp the transported item while the rollers are in the raised position.

8. Maintenance and Inspection

When the roller is dirty, clean it with a cloth using low-viscosity lubricating.

9. Inquiry

Should this product operate abnormally or should you have any questions, please contact us or the store/ agent where you purchased it.

※The specification and appearance of this product are subject to change without notice due to the need for improvement.

株式会社フリーベアコーポレーション

Freebear Corporation

発行：2024.08.01_ver.1.0